



深圳市国显科技股份有限公司

Shenzhen K&D Technology Co. Ltd

- Preliminary Specification
- Approval Specification

**SPECIFICATION
FOR
LCD MODULE**

Customer : _____
 Product Model: KD101N9-40TA-A37
 Sample code: _____

Designed by	Checked by	Approved by
Liyang Liu	Huaxing Li	Junhua Zhang

Final Approval by Customer

<input type="checkbox"/> LCM Machinery OK Checked By _____ <input type="checkbox"/> LCM Display OK Checked By _____	<input type="checkbox"/> LCM OK <input type="checkbox"/> NG, Problem survey: Approved By _____
--	--

※ The specification of "TBD" should refer to the measured value of sample . If there is difference between the design specification and measured value, we naturally shall negotiate and agree to solution with customer.

Revision History

Version	Contents	Date	Note
A0	Original	2015.05.15	

Contents

No.	Item	Page
1.	Numbering System	4/18
2	Scope	5/18
3	Normative Reference	5/18
4	Definitions	5/18
5	Block Diagram	7/18
6	Technology Specifications	7/18
7	Reliability Test	15/18
8	Handling Precautions	15/18
9	Precaution for use	16/18
10	Package Drawing	17/18
11	Outline Dimension	18/18

1. Numbering System

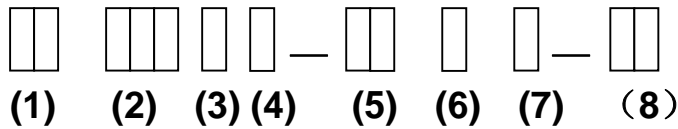

No	Definition	Specifications
(1)	TFT LCM Productor No.	KD ---- Kingdisplay technology Co.,Ltd
(2)	Display monitor opposite angle line size	Unit :mm (size <10 inch: takes two integers ; size >=10 inch: takes three integers)
(3)	Productor Types	D ---- PMP / Tablet PC G ----GPS M ----MP P ----Mobile-Phone N ----Net Book / Notebook / MID o o o
(4)	Productor Development Series No.	By two figures characters expression from 1 to 99
(5)	Interface PIN Number	By two figures characters expression from 1 to 99
(6)	With Touch Panel Or Not	T----With T/P ; N----Without T/P
(7)	LCD Type	A----AUO ; M----CMI ; C----CPT; B----BOE; L----LG; W----Wintek; H----HSD; S----Century T----Tianma ; Y----Hydis ; I----INNOLUX ; U---Samsung; V---- IVO; P---- Panasonic
(8)	Productor Development edition No.	By The English letters : A1~ Z999

2. Scope

This specification applies to the TFT LCD module which is designed and manufactured by LCM Factory of Shenzhen K&D Technology Co. Ltd.

3. Normative Reference

GB/T4619-1996 《Liquid Crystal Display Test Method》

GB/T2424 《Basic environmental Testing Procedures for Electric and Electronic Products.》

GB/T2423 《Basic Testing Procedures for Electric and Electronic Products》

IEC61747-1 《SIXTH PARTGB2828`2829-87 《National Standard of PRC》

4. Definitions

4.1 Definitions of Vop

The definitions of threshold voltage Vth1, Vth2 the following typical waveforms are applied on liquid crystal by the method of equalized voltage for each duty and bias.

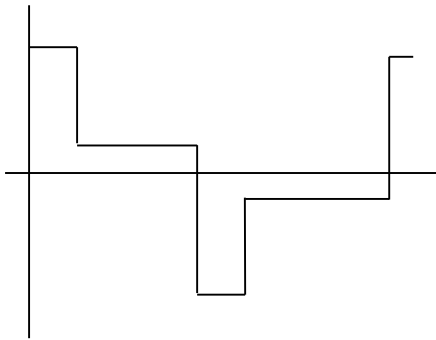

【 selected waveform 】

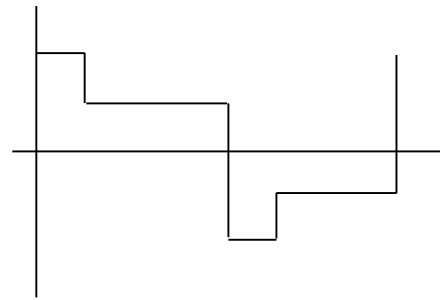

【 non-selected waveform 】

① Vth1: The voltage which the brightness of segment indicates 50% of saturated value on the conditions of selected waveform

($f_r=80\text{Hz}$, $\Phi=10^\circ$ $\theta=270^\circ$ at 25°C)

② Vth2: The voltage which the brightness of segment indicates 50% of saturated value on the conditions of non-selected waveform

($f_r=80\text{Hz}$, $\Phi=10^\circ$ $\theta=270^\circ$ at 25°C)

③ Vop: $(V_{th1}(50\%)+V_{th2}(50\%))/2$ ($f_r=80\text{Hz}$, $\Phi=10^\circ$ $\theta=270^\circ$ at 25°C)

4.2 Definition of Response Time Tr, Td

①Tr: The time required which the brightness of segment becomes 10% from 100% when waveform is switched to selected one from non-selected one. ($f_r=80\text{Hz}$, $\Phi=10^\circ$ $\theta=270^\circ$ at 25°C)

②Td: The time required which the brightness of segment becomes 90% from 10% when waveform is switched to selected one from selected one. ($f_r=80\text{Hz}$, $\Phi=10^\circ$ $\theta=270^\circ$ at 25°C)

4.3 Definition of Contrast Ratio Cr

$Cr=A/B$

- ① A: Segments brightness in case of non-selected waveform
- ② B: Segments brightness in case of selected waveform

4.4 Definition of Angle and Viewing Range

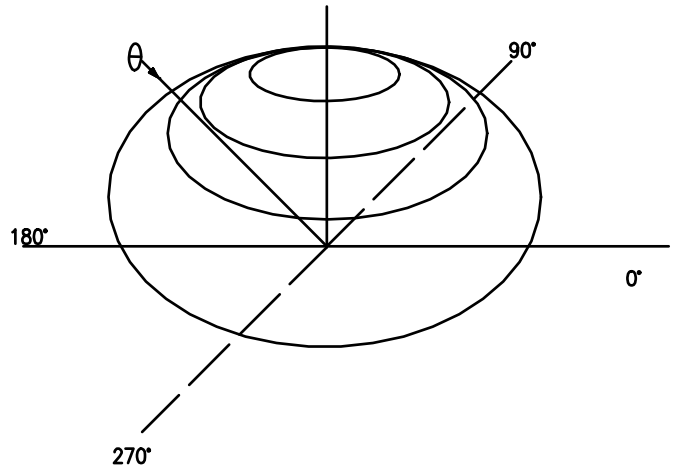
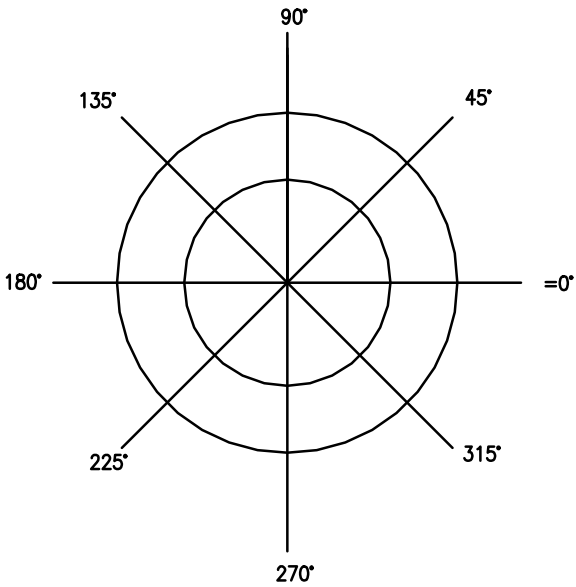

Angular Graph: Constrast Ratio

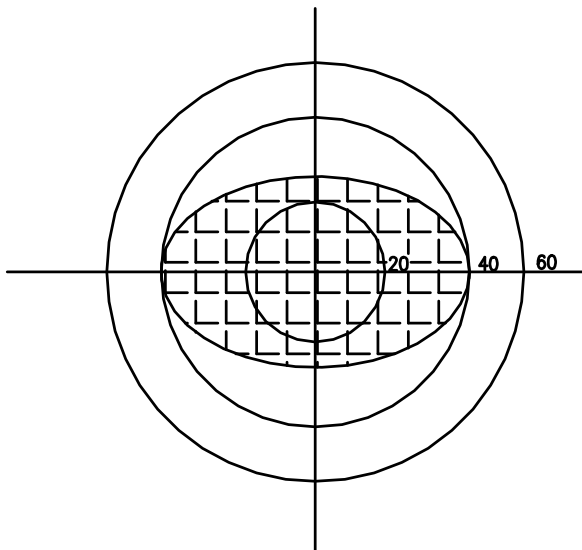

Such as:
Viewing Angle Range:
80(Cr>2) Horizontal
70(Cr>2) Vertical

5. Block Diagram

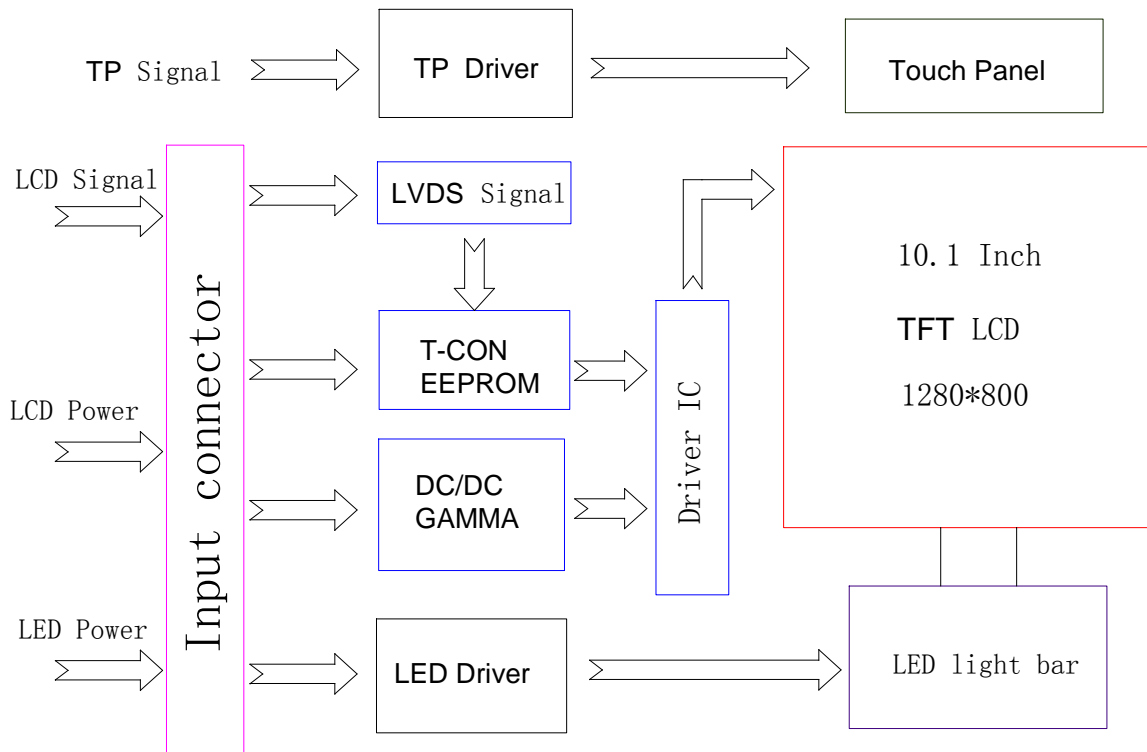

6. Technology Specifications

6.1 Features

This single-display module is suitable for use in MID products. The LCD adopts one backlight with High brightness 36-lamps white LED. Construction: 10.1 " a-Si color TFT-LCD ,With AUO Cell, White LED backlight, FPC ,T-CON and CTP.

6.2 General Specifications

No.	Item	Specification
1	LCD size	10.1 inch
2	Resolution	1280 (RGB)X800
3	Display mode	Normally black
4	Pixel pitch	0.1695(H)X0.1695(V) mm
5	Active area	216.96 (H)X135.60 (V) mm
6	LCM size	229.46(H)X149.10(V)X2.37(T)mm
7	LCM & CTP size	252(H)X165.87(V)X3.82(T)mm
8	Pixel arrangement	RGB-stripe
9	Surface Treatment	HC, Hardness 2H
10	Interface	LVDS (8 bit)
11	Backlight power consumption	3W(typ)
12	Panel power consumption	0.83W(typ)
13	Luminance for LCM	350 cd/m ² (typ)

6.3 Absolute Max. Rating

Item	Symbol	Values		Unit
		Min.	Max.	
Power Voltage	V _{DD}	-0.5	5.0	V
	V _{LED}	-0.5	15	V
Backlight forward current	I _{LED}	0	25	mA(For each LED)
Input Signal Voltage	V _I	-0.3	V _{DD}	V
Operation Temperature	T _{OP}	-10	50	°C
Storage Temperature	T _{ST}	-20	60	°C

6.4 Typical Operation Conditions

Item	Symbol	Values			Unit
		Min.	Typ.	Max.	
Power Voltage	V _{DD}	3.0	3.3	3.6	V
	V _{LED}	5	12	15	V
Current Consumption	I _{CC}	-	250	-	mA
	I _{VLED}	-	250	-	mA

6.5 Interface Pin Connection

Connector is used for electronics interface. The recommended model is 111A40-0000RA-G3 manufactured by CEMG.

Pin No.	Symbol	Function
1	NC	No Connection(Reserve)
2	VDD	Power Supply,3.3V(typical)
3	VDD	Power Supply,3.3V(typical)
4	NC	No Connection(Reserve)
5	NC	No Connection(Reserve)
6	NC	No Connection(Reserve)
7	NC	No Connection(Reserve)
8	Rin0-	- LVDS differential data input
9	Rin0+	+ LVDS differential data input
10	GND	Ground
11	Rin1-	- LVDS differential data input
12	Rin1+	+LVDS differential data input
13	GND	Ground
14	Rin2-	- LVDS differential data input
15	Rin2+	+LVDS differential data input
16	GND	Ground
17	ClkIN-	-LVDS differential clock input
18	ClkIN+	+LVDS differential clock input

19	GND	Ground
20	Rin3-	- LVDS differential data input
21	Rin3+	+LVDS differential data input
22	GND	Ground
23	NC	No Connection(Reserve)
24	NC	No Connection(Reserve)
25	GND	Ground
26	NC	No Connection(Reserve)
27	NC	No Connection(Reserve)
28	GND	Ground
29	NC	No Connection(Reserve)
30	NC	No Connection(Reserve)
31	GND	Ground
32	GND	Ground
33	GND	Ground
34	NC	No Connection(Reserve)
35	PWM	LED BLU Brightness Control(Note 1,2)
36	LED-EN	LED Converter Enable(3.3V)
37	NC	No Connection(Reserve)
38	VLED	LED Converter Input Power
39	VLED	LED Converter Input Power
40	VLED	LED Converter Input Power

Note1: PWM is used to adjust the B/Lbrightness.

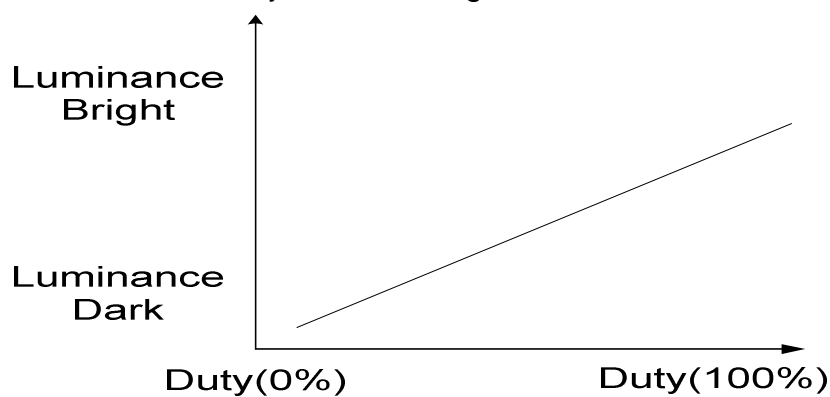

Note 2: PWM signal=0~3.3V, Operation Frequency:100 Hz~100KHz,

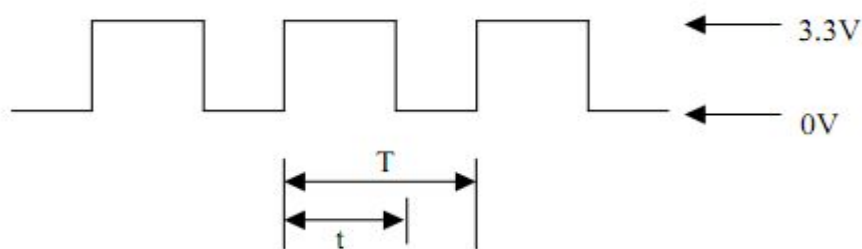

$$\text{Duty Cycle} = t / T * 100\%$$

$$T = 1 / F$$

6.6 Power Sequence

1) Power on/off sequence

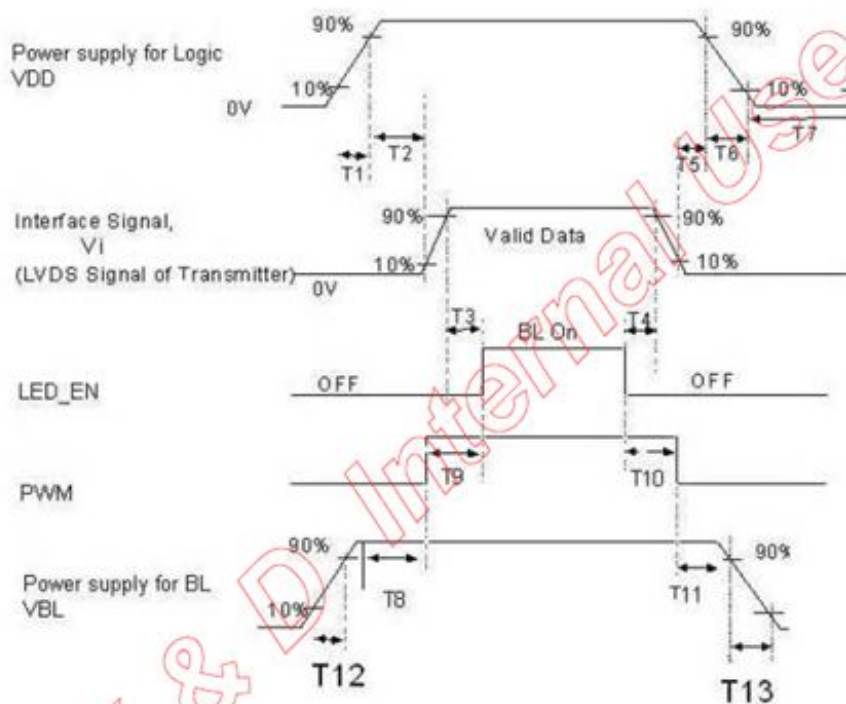

Parameter	Value			Unit
	Min.	Typical	Max.	
T1	0.5	-	10	[ms]
T2	0	40	50	[ms]
T3	200	-	-	[ms]
T4	200	-	-	[ms]
T5	0	16	50	[ms]
T6	0	-	10	[ms]
T7	500	-	-	[ms]
T8	10	-	-	[ms]
T9	0	-	180	[ms]
T10	0	-	180	[ms]
T11	10	-	-	[ms]
T12	0.5	-	10	[ms]
T13	0	-	10	[ms]

6.7 Timing Conditions

Basically, interface timings should match the 1280x800 /60Hz manufacturing guide line timing.

Parameter	Symbol	Min.	Typ.	Max.	Unit	
Frame Rate	---	---	60	---	Hz	
Clock frequency	$1/T_{Clock}$	---	66.1	69	MHz	
Vertical Section	Period	T_V	---	810	---	
	Active	T_{VD}	800			T_{Line}
	Blanking	T_{VB}	8	10	---	
Horizontal Section	Period	T_H	---	1360	---	
	Active	T_{HD}	1280			T_{Clock}
	Blanking	T_{HB}	48	80	---	

Note : DE mode only

Timing Diagram

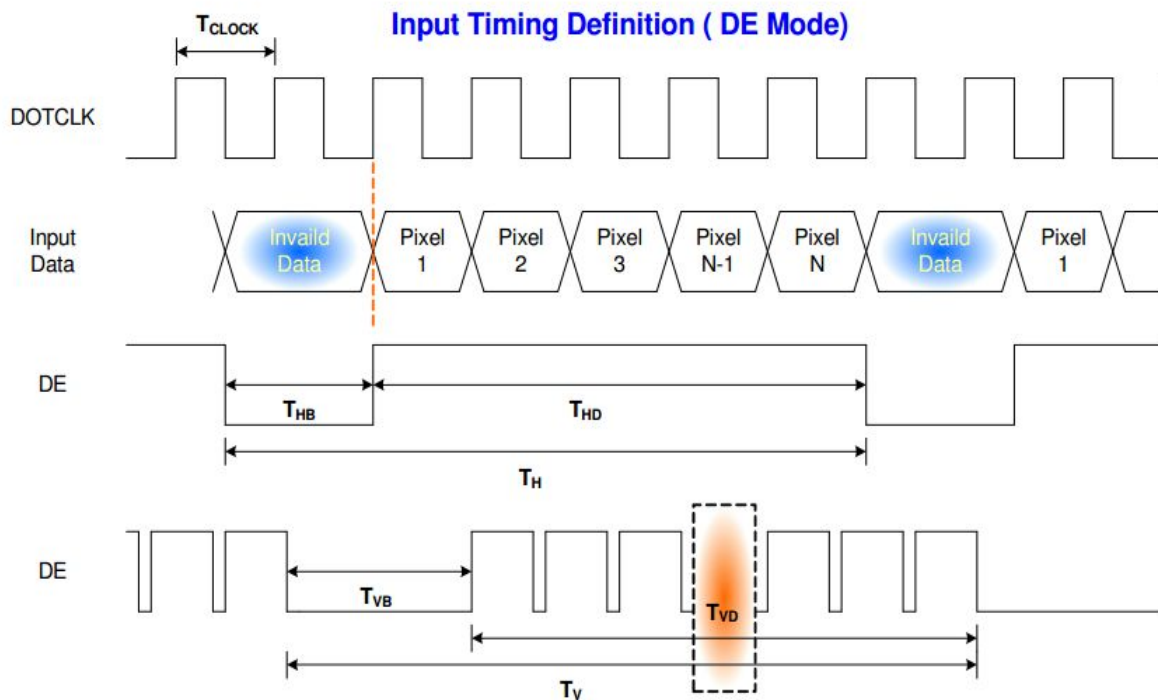

6.8 The Input Data Format

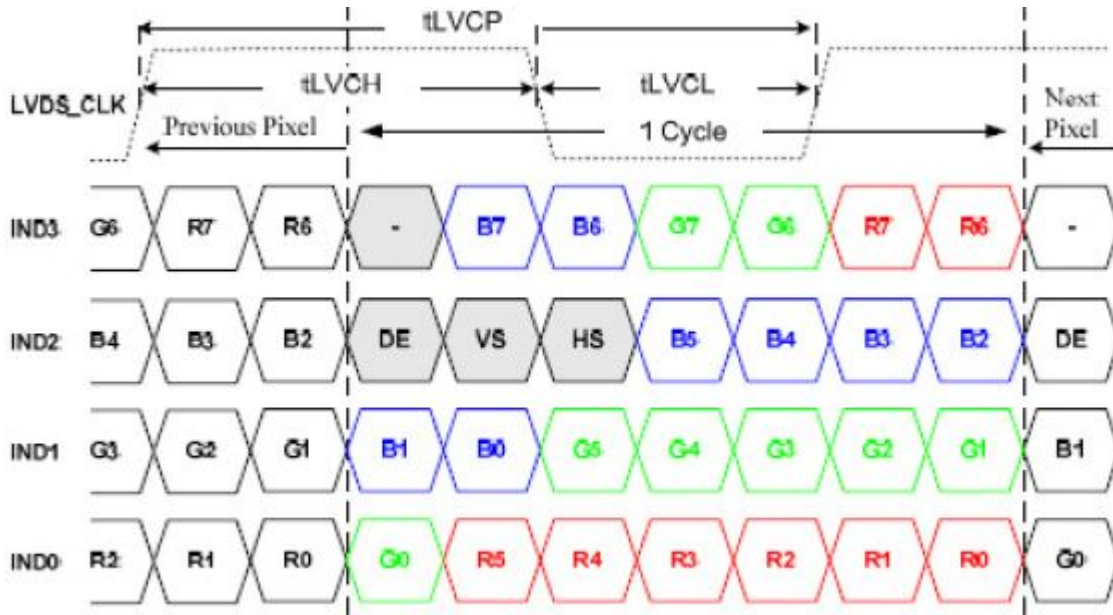

6.9 Optical specifications

Item	Symbol	Condition	Values			Unit	Remark
			Min.	Typ.	Max.		
Viewing angle (CR ≥ 10)	θ_L	$\Phi=180^\circ$ (9 o'clock)	-	85	-	degree	Note 1
	θ_R	$\Phi=0^\circ$ (3 o'clock)	-	85	-		
	θ_T	$\Phi=90^\circ$ (12 o'clock)	-	85	-		
	θ_B	$\Phi=270^\circ$ (6 o'clock)	-	85	-		
Response time Rise+Fall	T_{RT}	Normal $\theta=\Phi=0^\circ$	-	30	-	msec	Note 3
Contrast ratio	CR		600	800	-	-	Note 4
Color chromaticity	W_X		0.283	0.313	0.343	-	Note 2
	W_Y		0.299	0.329	0.359	-	Note 5 Note 6
Luminance	L		300	350	-	-	Note 6
Luminance uniformity	Y_U		70	75	-	%	Note 6,7

Note 1: Definition of viewing angle range

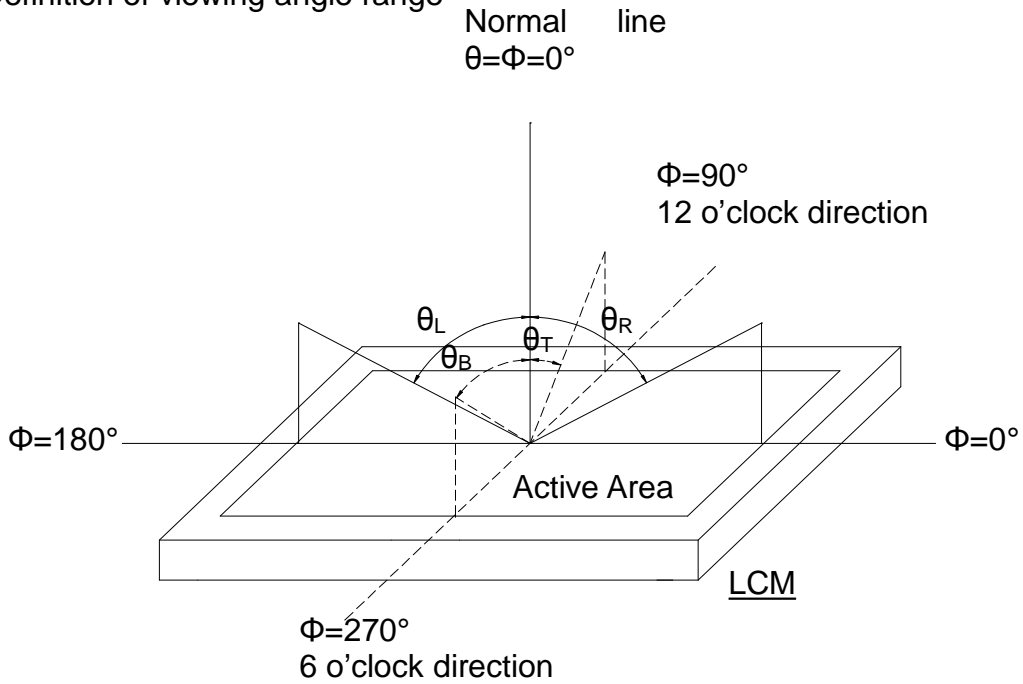

Fig. 4-1 Definition of viewing angle

Note 2: Definition of optical measurement system.

The optical characteristics should be measured in dark room. After 30 minutes operation, the optical properties are measured at the center point of the LCD screen. (Viewing angle is measured by ELDIM-EZ contrast/Height :1.2mm ,Response time is measured by Photo detector TOPCON BM-7, other items are measured by BM-5A/Field of view: 1° /Height: 500mm.)

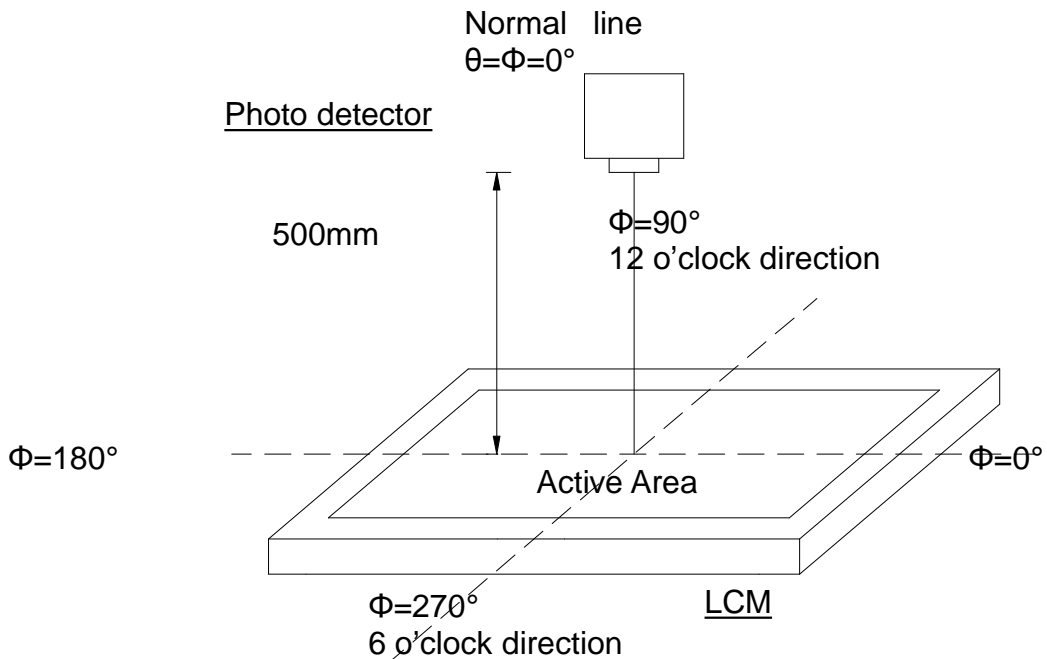

Fig. 4-2 Optical measurement system setup

Note 3: Definition of Response time

The response time is defined as the LCD optical switching time interval between “White” state and “Black” state. Rise time (T_{ON}) is the time between photo detector output intensity changed from 90% to 10%. And fall time (T_{OFF}) is the time between photo detector output intensity changed from 10% to 90%.

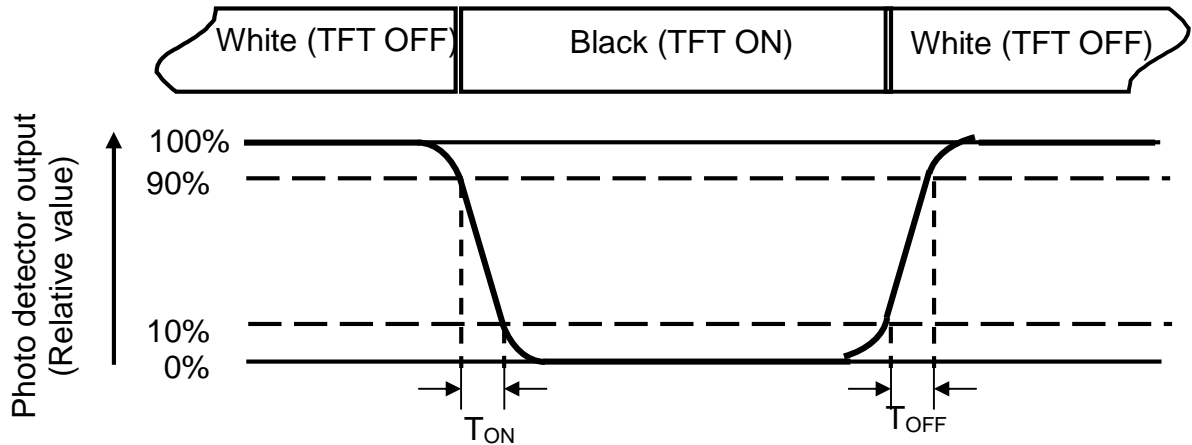

Fig. 4-3 Definition of response time

Note 4: Definition of contrast ratio

$$\text{Contrast ratio (CR)} = \frac{\text{Luminance measured when LCD on the "White" state}}{\text{Luminance measured when LCD on the "Black" state}}$$

Note 5: Definition of color chromaticity (CIE1931)

Color coordinates measured at center point of LCD.

Note 6: All input terminals LCD panel must be ground while measuring the center area of the panel. The LED driving condition is $V_{LED}=12V$

Note 7: Definition of Luminance Uniformity

Active area is divided into 9 measuring areas (Refer to Fig. 4-4).Every measuring point is placed at the center of each measuring area.

$$\text{Luminance Uniformity (Yu)} = \frac{B_{min}}{B_{max}}$$

L-----Active area length W----- Active area width

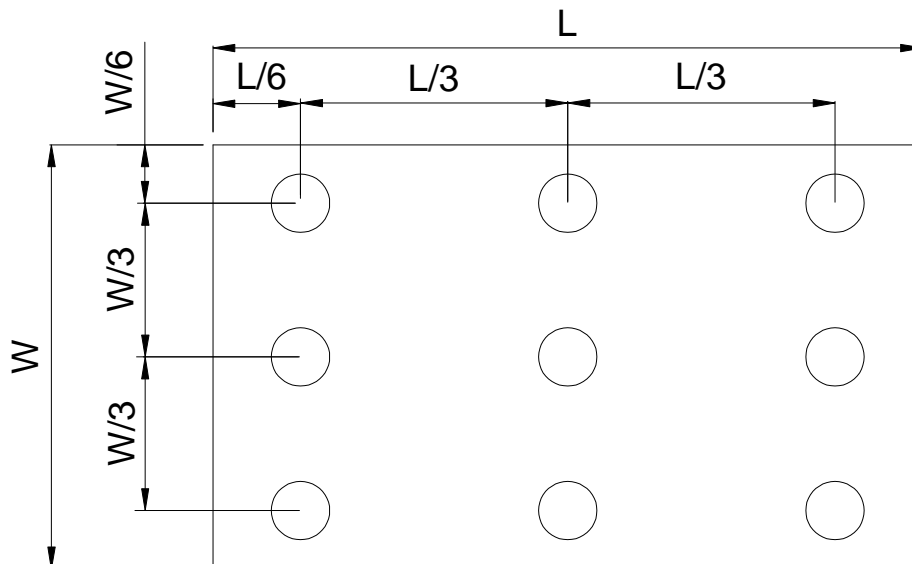

Fig. 4-4 Definition of measuring points

B_{max} : The measured maximum luminance of all measurement position.

B_{min} : The measured minimum luminance of all measurement position.

7. Reliability Test Conditions And Methods

Item	Test Conditions	Remark
High Temperature Storage	Ta = 60°C 96hrs	
Low Temperature Storage	Ta = -20°C 96hrs	
High Temperature Operation	Ts = 50°C 96hrs	
Low Temperature Operation	Ta = -10°C 96hrs	
Operate at High Temperature and Humidity	+50°C, 90%RH max. 96 hrs	Operation
Thermal Shock	-20°C~ +60°C 10 cycles 1Hrs/cycle	Non-operation
Electrostatic Discharge	Contact=±4KV, class B Air=±8KV, class B	

8. Handling Precautions

8.1 Mounting method

The LCD panel of K&D LCD module consists of two thin glass plates with polarizes which easily be damaged. And since the module in so constructed as to be fixed by utilizing fitting holes in the printed circuit board.

Extreme care should be needed when handling the LCD modules.

8.2 Caution of LCD handling and cleaning

When cleaning the display surface, Use soft cloth with solvent [recommended below] and wipe lightly

- Isopropyl alcohol
- Ethyl alcohol

Do not wipe the display surface with dry or hard materials that will damage the polarizer surface.

Do not use the following solvent:

- Water
- Aromatics

Do not wipe ITO pad area with the dry or hard materials that will damage the ITO patterns

Do not use the following solvent on the pad or prevent it from being contaminated:

- Soldering flux
- Chlorine (Cl) , Salfur (S)

If goods were sent without being sili8con coated on the pad, ITO patterns could be damaged due to the corrosion as time goes on.

If ITO corrosion happen by miss-handling or using some materials such as Chlorine (Cl), Salfur (S) from customer, Responsibility is on customer.

8.3 Caution against static charge

The LCD module use C-MOS LSI drivers, so we recommended that you:

Connect any unused input terminal to Vdd or Vss, do not input any signals before power is turned on, and ground your body, work/assembly areas, assembly equipment to protect against static electricity.

8.4 packing

- Module employ LCD elements and must be treated as such.
- Avoid intense shock and falls from a height.
- To prevent modules from degradation, do not operate or store them exposed direct to sunshine or high temperature/humidity

8.5 Caution for operation

- It is an indispensable condition to drive LCD's within the specified voltage limit since the higher voltage then the limit cause the shorter LCD life.
- An electrochemical reaction due to direct current causes LCD's undesirable deterioration, so that the use of direct current drive should be avoided.
- Response time will be extremely delayed at lower temperature then the operating temperature range and on the other hand at higher temperature LCD's how dark color in them. However those phenomena do not mean malfunction or out of order with LCD's, which will come back in the specified operation temperature.
- If the display area is pushed hard during operation, some font will be abnormally displayed but it resumes normal condition after turning off once.
- A slight dew depositing on terminals is a cause for electro-chemical reaction resulting in terminal open circuit.

Usage under the maximum operating temperature, 50%Rh or less is required.

8.6 storage

In the case of storing for a long period of time for instance, for years for the purpose or replacement use, the following ways are recommended.

- Storage in a polyethylene bag with the opening sealed so as not to enter fresh air outside in it . And with no desiccant.
- Placing in a dark place where neither exposure to direct sunlight nor light's keeping the storage temperature range.
- Storing with no touch on polarizer surface by the anything else.

[It is recommended to store them as they have been contained in the inner container at the time of delivery from us

8.7 Safety

- It is recommendable to crash damaged or unnecessary LCD's into pieces and wash off liquid crystal by either of solvents such as acetone and ethanol, which should be burned up later.
- When any liquid leaked out of a damaged glass cell comes in contact with your hands, please wash it off well with soap and water

9. Precaution for use

9.1

A limit sample should be provided by the both parties on an occasion when the both parties agreed its necessity. Judgment by a limit sample shall take effect after the limit sample has been established and confirmed by the both parties.

9.2

On the following occasions, the handing of problem should be decided through discussion and agreement between responsible of the both parties.

- When a question is arisen in this specification

- When a new problem is arisen which is not specified in this specifications
- When an inspection specifications change or operating condition change in customer is reported to K&D , and some problem is arisen in this specification due to the change
- When a new problem is arisen at the customer's operating set for sample evaluation in the customer site.

10. Package Drawing

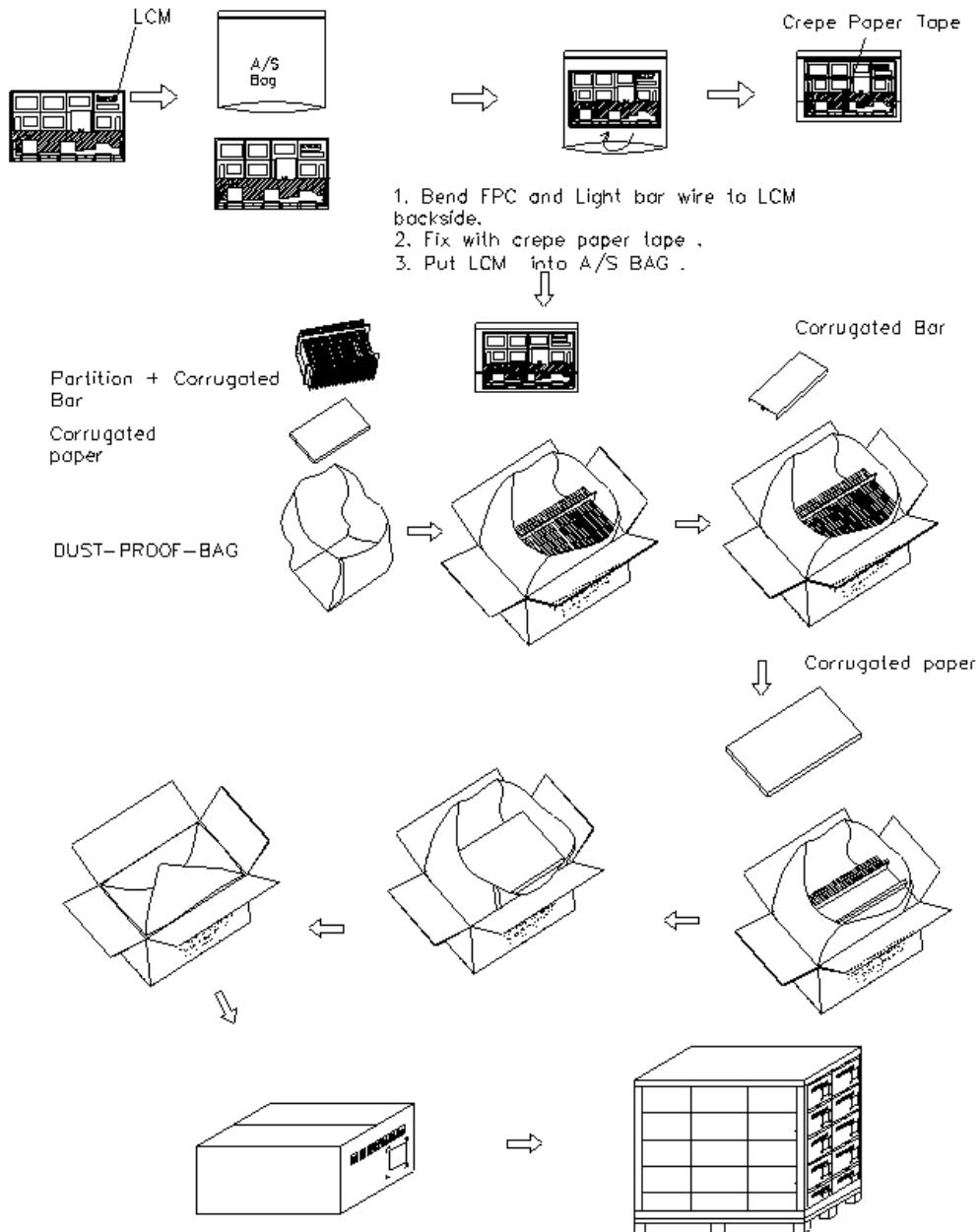

11. Outline Dimension

